



Manhole Products

84" Type 2 Precast Catch Basin
WSDOT B-10.20-03

Square Risers Available

- 2", 3", 4", 6", 12", 24" Solid or w/ Knockouts

Grade Adjustment Rings Available

- 2", 3", 4", 6"

Hole or Knock Out Dimensions

- Maximum hole size is 72 inches
- 12 inches of minimum distance between holes
- 3 inch diameter lifting holes provided
- Cored, cast-in and custom block-out/knock-outs available

Conformity Standards

- ASTM C478 Manhole
- ASTM C443 rubber gasket joint
- ASTM D4101 polypropylene steps and ladders
- Washington State APWA / WSDOT Standard

Options Available

- 2 foot minimum sump
- Specialized coatings
- Custom hatches
- Kor-N-Seal boots
- 1' thru 10' Polypropylene ladders
- Round offset & center hole flat tops
- Mastic

Section Specifications

Height Section

12"	2,534 LBS
24"	5,125 LBS
36"	7,716 LBS
48"	10,308 LBS
60"	12,899 LBS
72"	15,490 LBS
84"	18,081 LBS
96"	20,665 LBS

Base Slab	Flat Top
7,846 LBS	8,397 LBS

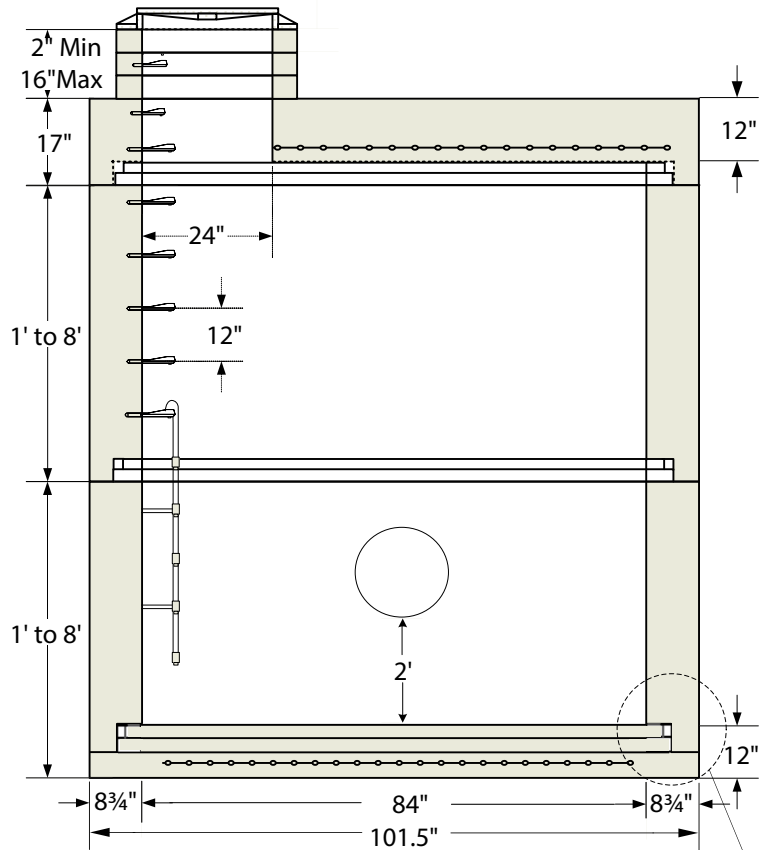

Top Slab Plan View

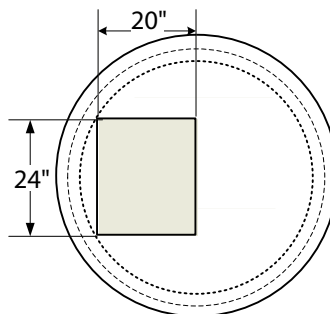

Gasket Shown Uncompressed

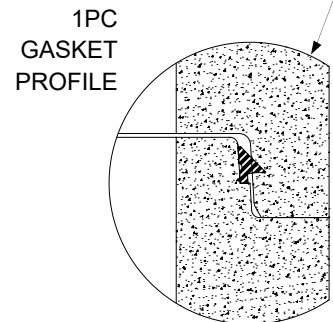

Note: Drawings not to scale

www.shopeconcrete.com

1-800-422-7560 [TOLL FREE]



Shope Concrete, LLC
 1618 East Main Avenue
 Puyallup, WA 98372-3142

(253) 848-1551
 Fax Line 1 (253) 845-0292
 Fax Line 2 (253) 864-6172

